

Ariete NS6200



From the world leader in high pressure homogenization: absolute quality and reliability with advanced technical solutions for any process need.

LIQUID END

- High quality stainless steel and special high wear resistance materials for best mechanical and corrosion resistance performances
- 3A and electropolished versions available
- Ball (PVB) and poppet valves (PVP) interchangeable into the same block design for maximum product handling flexibility
- Aseptic version compression block available with sterile condensate packing flushing
- Various materials for pumping plungers

HOMOGENIZING VALVE

- One stage (standard on homogenizers) with pneumatic adjustment from the machine's control panel
- High efficiency design valve NanoVALVE™, based on advanced fluid dynamics concepts, available as option
- Engineered for easy maintenance and cleaning
- Second stage option

POWER END

- Heavy duty and reliable power frame
- AC motor drive
- Forced lubrication with gear pump and low oil pressure switch
- 2 stage "V" belts drive train

CASING

- Made in polished stainless steel
- Easy access and maintenance with removable panels
- Noise reduction execution (≤ 80 dB) in full

TOOLS AND SPARE PARTS

- Special tools and one set of emergency spares parts supplied with the machine
- Manual and spare parts list on CD-ROM

Ariete NS6200

- Designed according to the EU safety rules (CE standards), engineered, manufactured and tested according to ISO EN 9001 Quality System
- Sanitary and aseptic execution, designed for CIP and SIP
- Suitable for abrasive and viscous products
- Homogenizing pressure up to 700 bar
- Monoblock compression head design
- Easy implementation in remote controlled systems and complete process lines

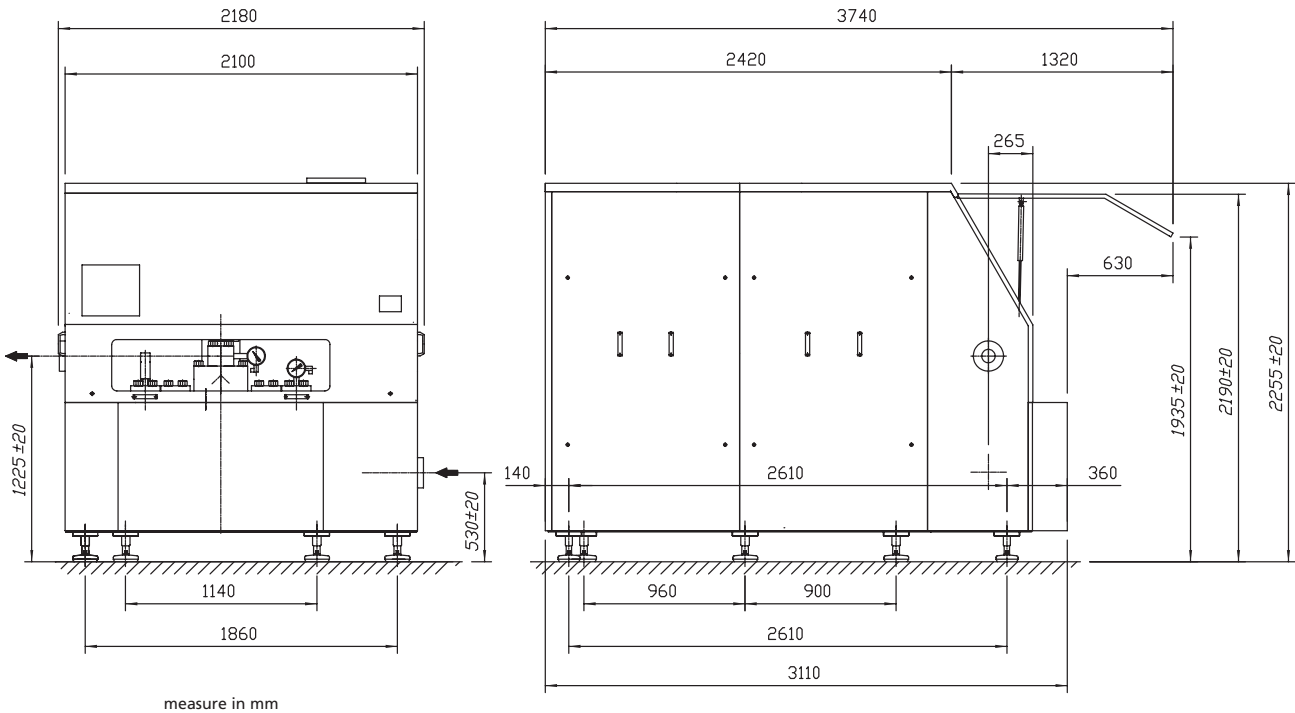

Technical specifications are not mandatory and subject to change without notice

PERFORMANCES

Pressure (bar)	Max Flow Rate (l/h)
100	40000
150	40000
200	31000
250	25000
400	16000
600	10800
700	9000
1000	-
1200	-

TECHNICAL DATA

Number of plungers	6
Stroke	100 mm
Absorbed motor power up to	200 kW
Weight	7000 kg
Water consumption	250 l/h
Lubricating oil ISO VG 150	125 l

COMPRESSION HEAD

- Special high grade Duplex / Super Duplex SS alloy
- Monoblock construction

PUMP VALVES

- High wear resistant Stellite™ alloy removable seats
- Ball type (PVB) or poppet type (PVP) in solid Stellite™

PISTONS

- Chrome coated stainless steel
- Tungsten carbide coated stainless steel
- Solid ceramic

HOMOGENIZING VALVE

- Pneumatic actuated
- Wear parts made of tungsten carbide, ceramics as option
- High efficiency NanoVALVE™ available as option

PRESSURE GAUGE

- Sanitary design analog high pressure gauge

PRODUCT LINE CONNECTIONS

- DIN 11851, TRI-Clamp™
- Tri-Clamp™
- Others as option upon request

POWER END

- Rugged cast iron power frame
- Forced lubrication with low oil pressure switch
- Totally enclosed sound proof execution with removable SS panels

MAIN OPTIONS

- high pressure pump version
- 2nd stage homogenizing valve
- electric power board for fixed or variable capacity

COMPANY
WITH QUALITY SYSTEM
CERTIFIED BY DNV
= ISO 9001/2000 =

edelflex
 Av. Belgrano 2487 - B1611DVD - Bs. As. - Argentina
 Tel.: + 54 11 4727 2000 - Fax: + 54 11 4727 2200
 www.edelflex.com - e-mail: info@edelflex.com

Via A. M. Da Erba Edoari, 29 - I - 43100 PARMA ITALY
 Tel. +39 0521.965411 - Fax +39 0521.242819
 www.niro-soavi.it

GEA Niro Soavi S.p.A.