

# Twin Panda

# NS2002H



**From the world leader in high pressure homogenization: absolute quality and reliability with advanced technical solutions for any process need.**

#### COMPRESSION BLOCK

- Manufactured in high grade and high performances super duplex stainless steel, the compression block is designed to ensure the maximum stress resistance to maximise the performances and reliability at high operating pressure
- Solid ceramic pumping plungers equipped with specially designed packings to avoid the need of lubrication water
- Suction and delivery ball valves (PVB) in Stellite™, with replaceable suction valve seat in Stellite™
- Analog pressure gauge, with built-in pulsation damper, with optional pressure transmitter (4-20 mA signal)

#### HOMOGENIZING VALVE

- Wear parts in tungsten carbide, fully reversible
- Manual pressure adjustment by means of a hand-wheel
- Second stage homogenizing valve group applied as standard
- Allow front/side/upwards outlet to match with plant piping layout

#### PRODUCT INLET/OUTLET

- Tri-Clamp™ connections for inline installation
- No feeding pump is needed ( for product viscosity up to 1000 cP )

#### POWER END

- Maintenance - free timing belt drive
- Three phase motor, suitable for variable speed drive
- Camshaft drive system and maintenance-free grease lubrication

#### CASING

- Panels made in polished stainless steel, completely removable for maintenance and cleaning
- High quality paint steel base frame
- Adjustable anti-vibration rubber feet

# Twin Panda NS2002H

- The TwinPanda is a small table-top laboratory /pilot unit designed for continuous operation up to 600 bar, suitable for microsizing tests on many different fluids and pilot scale process trials.
- The TwinPanda's flexibility makes it a useful tool for many different sectors, such as the food, dairy, chemical industries.

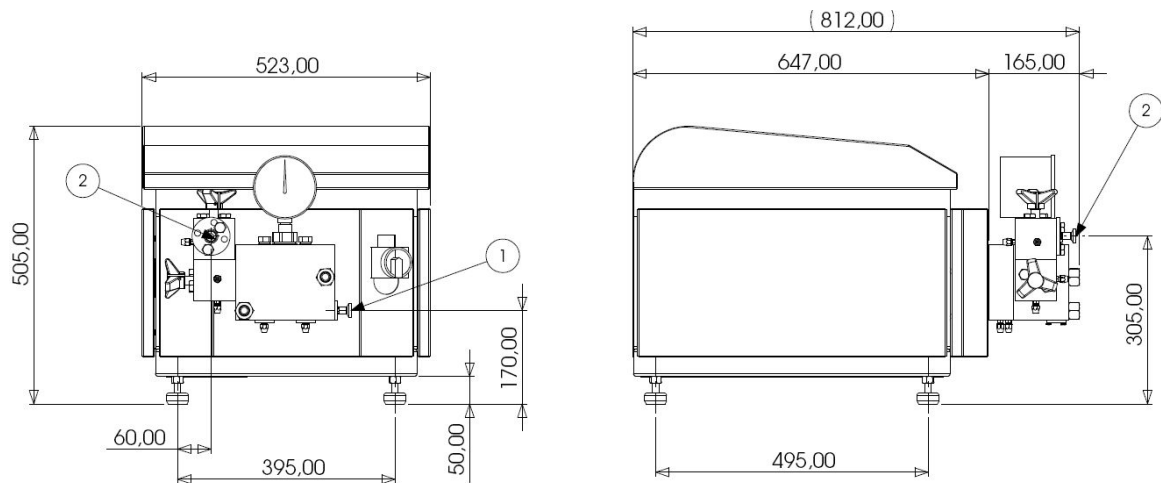

measure in mm

Technical specifications are not mandatory and subject to change without notice

## DESIGN FEATURES AND PERFORMANCES

Max operating pressure 600 bar

Flow rate of 30 l/h @ 600 bar - 55l/h @ 400 bar

Minimum sample volume approx 100 ml

Three-phase motor 1.5 kW @ 400V / 50 Hz

Weight 143 Kg

Dimensions mm W 460 x H 420 x L 800

Connections in/out 1/2" Tri-Clamp™

## MAIN FEATURES

- Compact design for easy installation, use and maintenance
- Suitable for viscous pumpable products, up to 1000 cP without feeding pump
- SS feeding hopper (2.5 l) supplied as standard
- 3A version available as option
- FDA approved gaskets, available as option
- Suitable for CIP/SIP
- Suitable for in-line installation, with Tri-Clamp™ connections to a feeding and a discharge tank
- Three-phase electricity is the only utility needed, the machine is supplied with in-built motor starter
- No need for cooling/lubrication water
- Aseptic version available as option
- Suitable for variable speed drive

**edelflex**

**Edelflex S.A.**

Av. Belgrano 2487 - B1611DVD - Don Torcuato  
Provincia de Buenos Aires - República Argentina  
Tel.: + 54 11 4727 2000 - Fax: + 54 11 4727 2200  
www.edelflex.com - info@edelflex.com

**COMPANY  
WITH QUALITY SYSTEM  
CERTIFIED BY DNV  
=ISO 9001/2000=**

**GEA Niro Soavi S.p.A.**

Via A. M. Da Erba Edoari, 29 - I - 43100 PARMA ITALY  
Tel. +39 0521.965411 - Fax +39 0521.242819  
www.niro-soavi.it