

Product Recovery Systems

... up to 99% recovery of valuable products



Using Tuchenhagen Product Recovery Systems .



. . .you regain valuable products from your pipe system and thus optimise the economic efficiency of your production plant. Residual products are expelled from the pipes and returned into the product flow by pigging. No more than a thin residual film remains in the pipe system that can easily be removed by subsequent cleaning (CIP). This technique reduces also the waste water load drastically.

Advantages using Product Recovery Systems:

- Reduced loss of valuable products
- Reduced production down times
- Reduced consumption of rinsing water
- Reduced consumption of cleaning media
- Reduced waste water load

Applications

1. Product push-outs

Product recovery systems are used whenever viscous products are expelled from pipe systems without the risk of intermixing with other media.

This is especially required for high quality products in industries from food and beverages through to pharmaceuticals and cosmetics.

2. Product handling

In addition to their primary application, Product Recovery Systems are also used for gentle filling of process pipework systems for sensitive products and products liable to foam. This is especially useful when filling vertical pipe-runs downwards where the pig is launched in front of the product.

Range of application in production plants

- from product reception to pre-mix tanks
- from pre-mix tanks to mixing/process tanks
- from mixing/process tanks to storage tanks
- from storage tanks to filler lines
- from treatment lines to storage tanks/filler lines

Applicable for Products as:

- Shampoos, lotions, creams, toothpaste
- Pharmaceutical liquid products
- Washing agents, cleaning agents,
- Yoghurt, quark, cheese
- Fruit pulp, syrup, concentrates
- Dough, vegetable oil
- Personal products
- Internal medicines

Pig cleaning station

The pocket-free design of the pig cleaning station is suitable for CIP and SIP. It is integrated into the product pipework and can be used either

as a launching or receiving station. Product or CIP solutions are transferred in either direction past the pig which is firmly held in the unit. through the station. The sta-

tion is designed so that the cross sectional area around the pig is the same as the pipework.

Pig

The pig is an inert flexible body made from wear and temperature resistant, product compatible material. Its contours allow safe cleaning of the entire surface; its shape ensures an optimal passage through small and large pipe bends and tees.

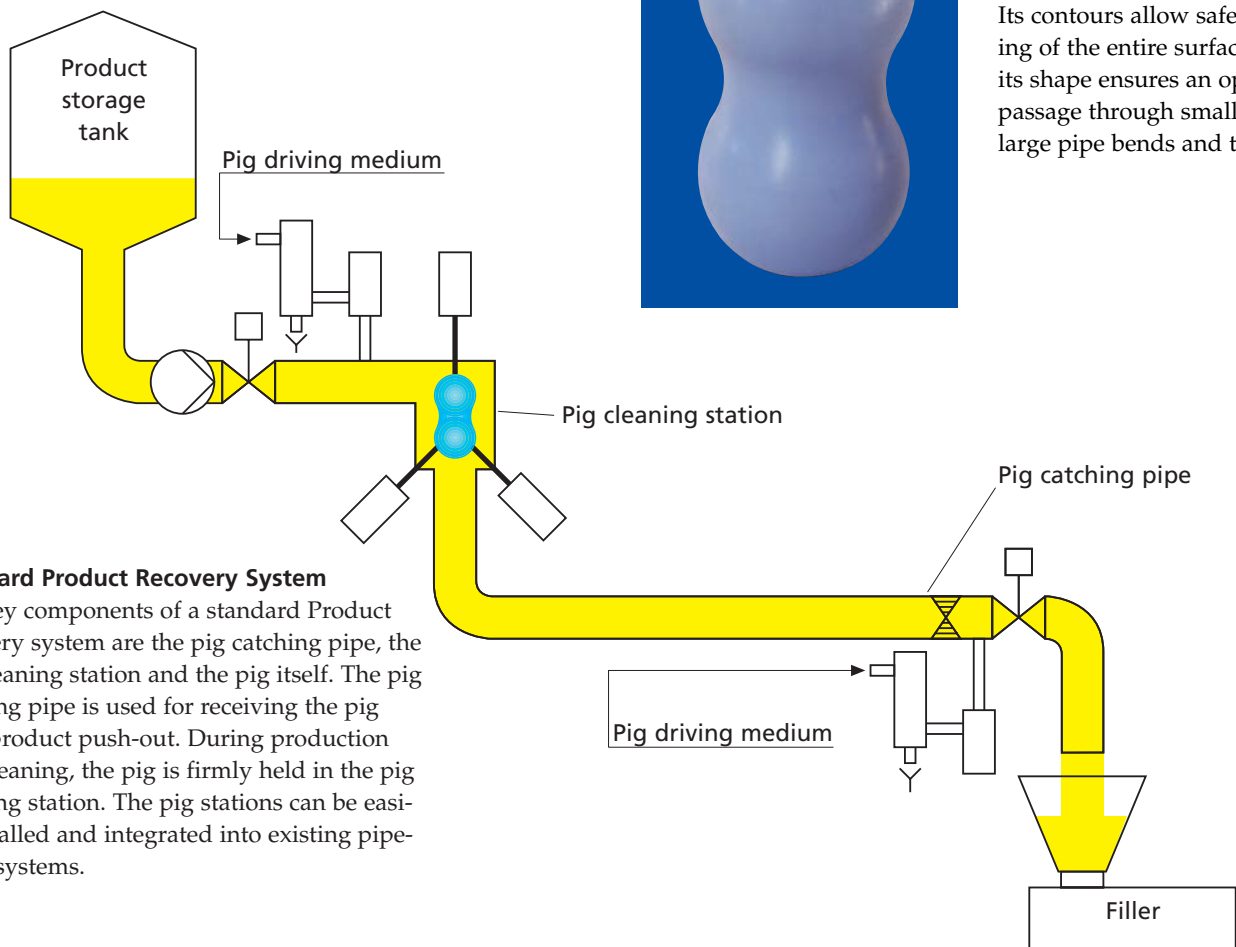

Standard Product Recovery System

The key components of a standard Product recovery system are the pig catching pipe, the pig cleaning station and the pig itself. The pig catching pipe is used for receiving the pig after product push-out. During production and cleaning, the pig is firmly held in the pig cleaning station. The pig stations can be easily installed and integrated into existing pipe-work systems.

Tuchenhagen Product Recovery Systems are noted for:

- their use in fully automated production lines with hygienic integrity
- automatic control of the pig by detection of the pig's position outside the pipe.
- safe operation due to the matrix piped, closed system.
- no disassembly of the pig stations for operational and cleaning purposes
- full integration into CIP and SIP systems for both new and existing plants
- fully automatic CIP/SIP-able pig stations
- supply valves for pig driving media pulsed during pipework CIP to guarantee full cleaning.
- fully verifiable processes
- product push-out forward or back to the source tank.
- use of different pig driving media: water, air, CO₂ or N₂

Process diagram

The following diagrams show the process sequences of a Tuchenhagen Product Recovery System where the pig cleaning station serves as launching station.

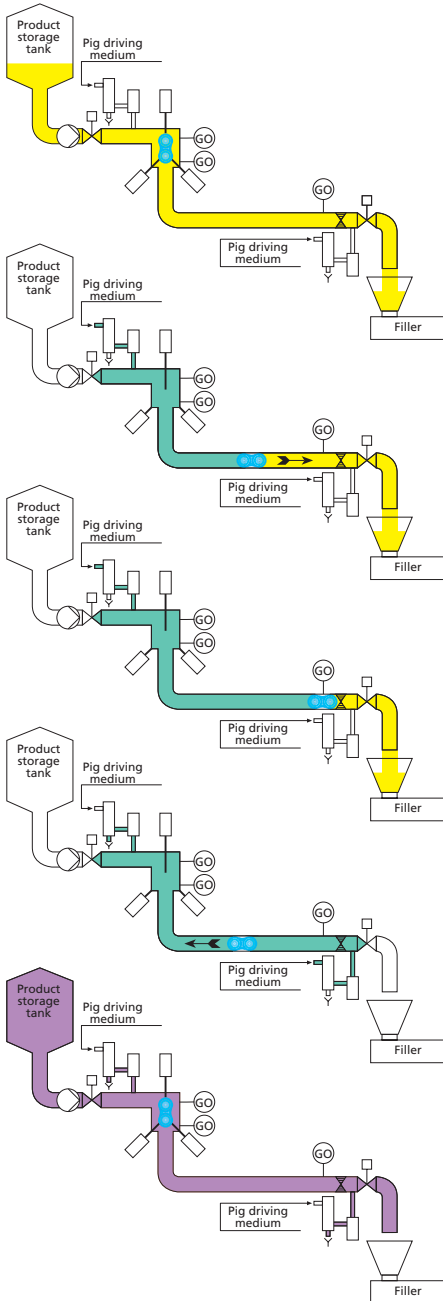

Production

The pig is firmly held in position in the launching station and flooded by the product.

Product push-out

The pig is pressed through the pipe by means of a driving medium and pushes the product into the filler.

Product push-out finish

Detection of the pig position in the pig catching pipe via a magnetic switch outside the pipe.

Pig return

The pig leaves the receiving station and is returned to the launching station by the driving medium.

Cleaning

The pig stations and driving medium supply valves are cleaned during the pipework CIP programme. The pig in the launching station is held in the CIP flow and completely cleaned.

Your Contact



Edelflex S.A.

Av. Gral. Belgrano 2487 B1611DVD - Don Torcuato
Partido de Tigre - Provincia de Buenos Aires - Argentina
Tel.: +54 11 4727-2000 - Fax: +54 11 4727-2200
www.edelflex.com - info@edelflex.com